

Image shown may not reflect
actual Engine

SPECIFICATIONS

I-6, 4-Stroke-Cycle-Diesel

Emissions.....	EPA-IMO
Displacement.....	11.95 L (729.23 in ³)
Rated Speed.....	2300
Bore.....	130.0 mm (5.12 in)
Stroke.....	150.0 mm (5.91 in)
Aspiration.....	TA
Governor.....	Electronic
Cooling System.....	Heat Exchanger
Weight, Net Dry (approx.).....	1,037 kg (2,286 lb)
Refill Capacity	
Cooling System.....	45.0 L (11.9 gal)
Lube Oil System.....	28.0 L (7.4 gal)
Oil Change Interval.....	250 hrs
Caterpillar Diesel Engine Oil 10W30 or 15W40	
Center Sump Oil Pan	
Rotation (from flywheel end).....	CCW
Flywheel and Flywheel Housing.....	SAE NO. 1
Flywheel Teeth	

STANDARD ENGINE EQUIPMENT

Air Inlet System

Corrosion resistant sea water aftercooler; air cleaner/fumes disposal system (closed)

Cooling System

Self priming gear driven sea water pump with rubber impeller, gear driven jacket water pump, integral heat exchanger/expansion tank with removable tube bundle and replaceable copper-nickel tubes, thermostat and housing

Exhaust System

Watercooled exhaust manifold and turbocharger, round flanged outlet

Fuel System

Fuel priming pump, fuel transfer pump, fuel filter - RH or LH service, flexible fuel lines

Instrumentation

Electric service meter

Lube System

Crankcase breather, engine oil cooler; oil filter - RH or LH service, oil level gauge - RH or LH service, oil filler, center sump oil pan, gear driven oil pump

Mounting System

Front support

Power Takeoffs

11 tooth spline SAE A hydraulic pump drive, single groove crankshaft pulley

Protection System

12 or 24 volt electronic shutdown (energized-to-run)

General

Vibration damper and guard, Caterpillar yellow paint, lifting eyes, variable engine wiring, customer wiring connector and service tool connector

ISO Certification

Factory-designed systems built at Caterpillar
ISO 9001:2000 certified facilities

PERFORMANCE CURVES

E-RATING - DM7530-01

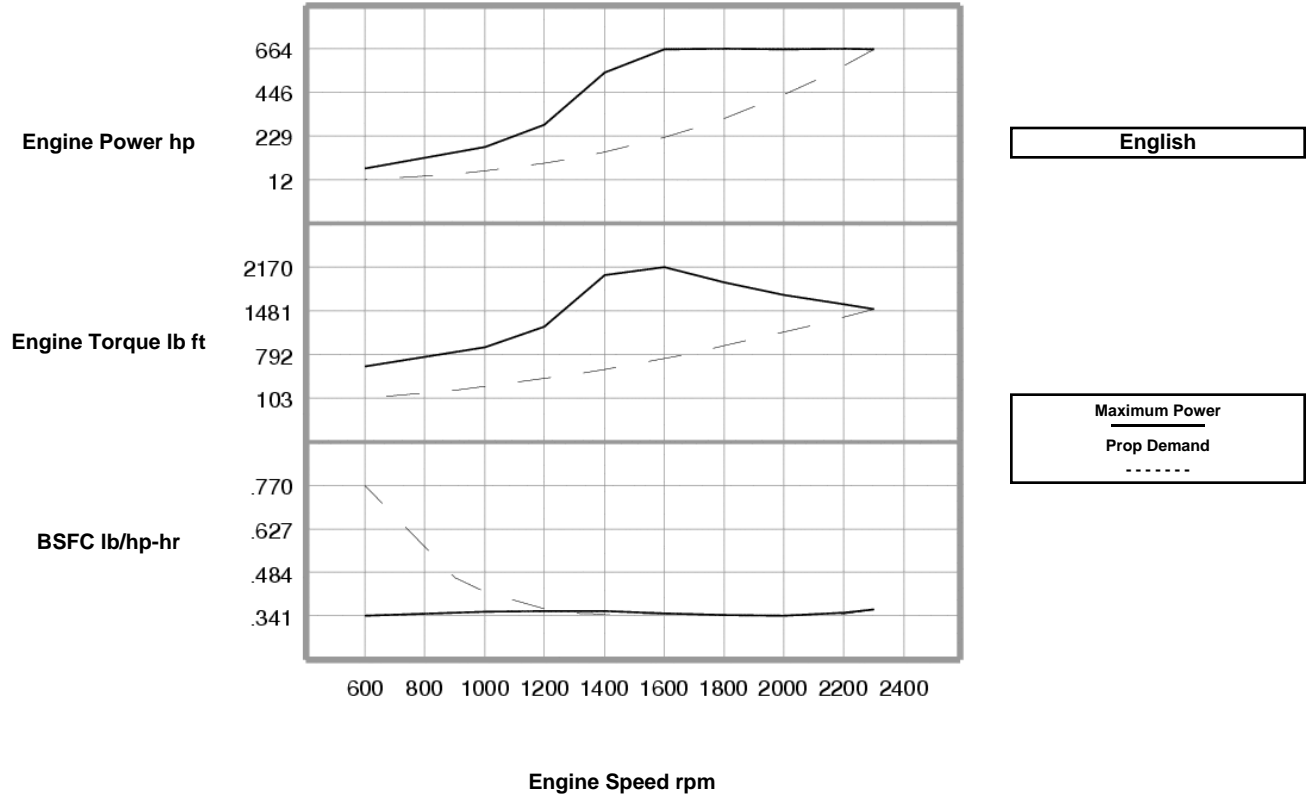

Maximum Power Data					Prop Demand Data				
Engine Speed rpm	Engine Power hp	Engine Torque lb ft	BSFC lb/hp-hr	Fuel Rate gph	Engine Speed rpm	Engine Power hp	Engine Torque lb ft	BSFC lb/hp-hr	Fuel Rate gph
2300	660	1507	.362	34.1	2300	660	1507	.362	34.1
2200	664	1584	.352	33.4	2200	577	1378	.347	28.6
2000	661	1735	.342	32.3	2100	502	1256	.340	24.4
1800	662	1932	.343	32.5	2000	434	1140	.340	21.1
1600	661	2170	.350	33.0	1800	316	923	.344	15.5
1400	545	2044	.355	27.7	1700	266	823	.346	13.2
1200	282	1235	.356	14.3	1600	222	729	.346	11.0
1000	172	904	.353	8.7	1400	149	558	.345	7.3
600	68	597	.340	3.3	1300	119	482	.349	5.9
					1200	94	410	.363	4.9
					1000	54	285	.419	3.2
					900	40	231	.467	2.6
					600	12	103	.770	1.3

NOTE: Prop demand data is a cubic prop demand curve with 3.0 exponent for displacement hulls only.

DIMENSIONS

Right Side

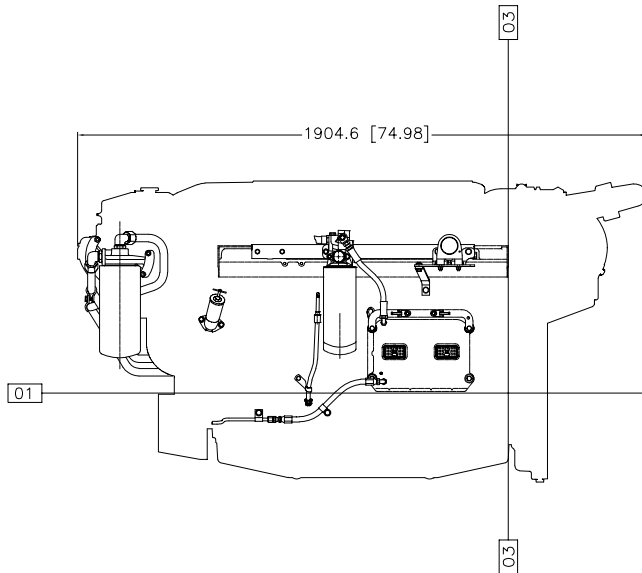

Front

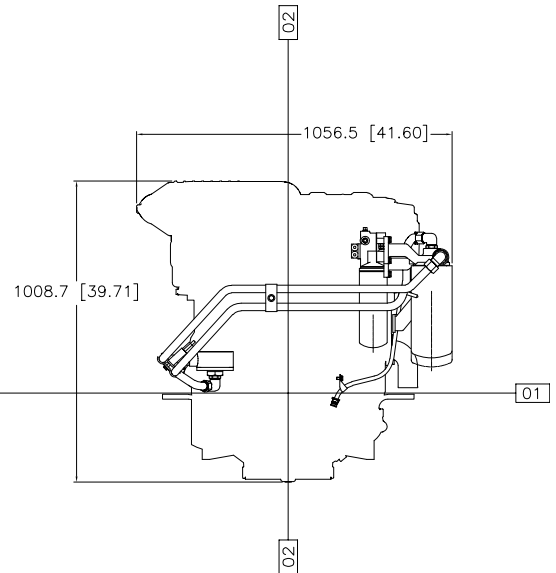

Engine Dimensions		
(1) Length to Flywheel Housing	Information not available at this time.	
(2) Width		
(3) Height		
Weight, Net Dry (approx)	1037 kg	2,286 lb

Note: Do not use for installation design. See general dimension drawings for detail (Drawing # null).

RATING DEFINITIONS AND CONDITIONS

E Rating (High Performance) -

% Load Factor: up to 30

% Time at Rated RPM: up to 8

Typical Time at Full Load: 1/2 hours out of 6

Typical Hour/Year: 250 to 1000

Typical Applications: For vessels operating at rated load and rated speed up to 8% of the time (up to 30% load factor). Typical applications could include but are not limited to vessels such as pleasure craft, harbor patrol boats, harbor master boats, some fishing or patrol boats. Typical operation ranges from 250 to 1000 hours per year.

Power

at declared engine speed is in accordance with ISO3046-1:2002E. Caterpillar maintains ISO9001:1994/QS-9000 approved engine test facilities to assure calibration of test equipment. Electronically controlled engines are set at the factory at the advertised power corrected to standard ambient conditions. The published fuel consumption rates are in accordance with ISO3046-1.

Fuel rates

are based on fuel oil of 35° API [16°C (60°F)] gravity having an LHV of 42 780 kJ/kg (18,390 Btu/lb) when used at 29°C (85°F) and weighing 838.9 g/L (7.001 lb/U.S. gal). Additional ratings may be available for specific customer requirements. Consult your Caterpillar representative for additional information.

Performance data is calculated in accordance with tolerances and conditions stated in this specification sheet and is only intended for purposes of comparison with other manufacturer's engines. Actual engine performance may vary according to the particular application of the engine and operating conditions beyond Caterpillar's control.

Power produced at the flywheel will be within standard tolerances up to 49° C (120° F) combustion air temperature measured at the air cleaner inlet, and fuel temperature up to 52° C (125°F) measured at the fuel filter base. Power rated in accordance with NMMA procedure as crankshaft power. Reduce crankshaft power by 3% for propeller shaft power.

Performance No.: DM7530-01

Feature Code: C12MC03

U.S. Sourced

11953213

28 March 2008

©2008 Caterpillar

All rights reserved.

Materials and specifications are subject to change without notice.

The International System of Units (SI) is used in this publication.

CAT, CATERPILLAR, SAFETY.CAT.COM their respective logos, "Caterpillar Yellow," and the POWER EDGE trade dress, as well as corporate and product identity used herein, are trademarks of Caterpillar and may not be used without permission.